

# MINI THEFT STOPPER



## STI MINI THEFT STOPPER

Protects free-standing and cabinet mounted fire extinguisher and other equipment.

The Mini Theft Stopper is an inexpensive yet highly effective way to protect fire extinguishers and a wide range of other fire fighting equipment from theft or misuse. The device is compact, highly effective and extremely versatile. It does not interfere with fire fighting in any way and its simplicity of design contributes to its high degree of reliability.

## HOW IT WORKS

### FOR FREE-STANDING EXTINGUISHER OR EQUIPMENT

The Mini Theft Stopper comes with a special clip that can be used in several ways. An extinguisher's pull pin may be routed through the holes in both prongs of the clip. The clip is then held in place by the extinguisher's seal and when the seal is broken to use the extinguisher, the alarm sounds. The steel clip can also be placed under any type of equipment. When lifted, the alarm sounds immediately.

### FOR CABINETS HOUSING FIRE EXTINGUISHER, FIRE HOSES OR SPRINKLER SHUT OFF VALVES.

The Mini Theft Stopper is mounted next to the door or in the cabinet and its reed switch unit is mounted in the door jam. The matching magnet is mounted on the door in close proximity. When the door is opened the device emits a 95 dB (at 1 metre) warning alarm.

## FEATURES

- Highly visible 'stop sign' design discourages wrongful use of extinguisher
- Sounds a powerful 95 dB (at 1 metre) warning alarm when activated drawing immediate attention
- Self contained 9 VDC alkaline power source is provided
- Two methods of operation – magnetic reed switch activation for cabinets and display cases and unique steel contact clip activation for fire extinguisher pins and other free-standing equipment
- Extremely cost effective and easy to install
- Deactivation pin provided for service by authorised personnel
- Three minute automatic reset upon activation
- Compact design (83mm/3.25" diameter and 25mm/1" deep) mounts easily next to the extinguisher
- Does not interfere with use of protected fire fighting equipment
- Tough, ABS construction

## MODELS AVAILABLE

- STI 6255** Mini Theft Stopper
- STI 6255/M2** Double Point Mini Theft Stopper (protects 2 extinguishers using 2 spring clips)

## ACCESSORIES

- E009** Deactivation pin

Specifications	
Housing	3mm/1/8" ABS
Dimensions	83mm/3.5" h x 83mm/3.5" w x 25mm/1" d
Sounder Output (at 1 metre)	95 dB
Operation	Steel Contact Clip Switch Magnetic Reed Switch
Standby Current	None
Alarm Current	115 mA
Auto Reset	3 Minutes

▼ Mini Theft Stopper dimensions and technical information (STI 6255)

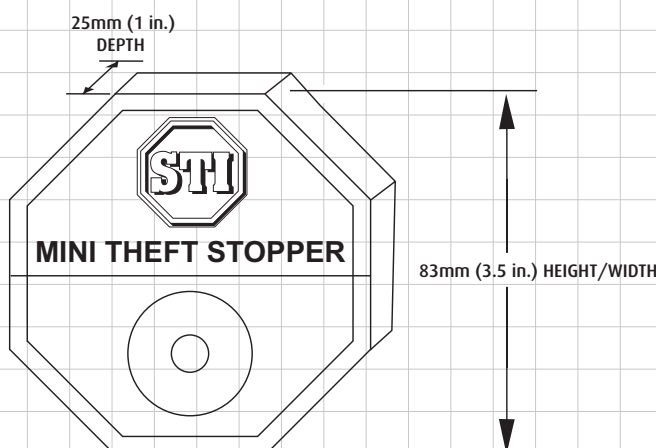

## SUPPLIED WITH TWO TYPES OF ACTIVATION

